



RM Series

85°C, Standard, Radial Leads

- Life 2000 hours at 85°C
- Small size allows wider choice of capacitance and voltage for automatic insertion.

Characteristics

Voltage Range	6.3 to 100 VDC	160 to 450 VDC																																		
Capacitance Range	0.47 to 10,000 μ F	0.47 to 470 μ F																																		
Temperature Range	-40 to +85°C	-25 to +85°C																																		
Capacitance Tolerance	\pm 20% at 120Hz, 20°C (10% Tol. is available upon request)																																			
Leakage Current	$I \leq 0.01CV$ or $3\mu A$, whichever is greater 3 minutes after Rated Voltage is applied	$I \leq 0.03CV$ or $3\mu A$, whichever is greater 3 minutes after Rated Voltage is applied																																		
Dissipation Factor (tan δ) Max.	<table border="1"> <tr> <td>Rated Voltage (V)</td> <td>6.3</td> <td>10</td> <td>16</td> <td>25</td> <td>35</td> <td>50</td> <td>63</td> <td>100</td> </tr> <tr> <td>D.F. (tan δ)</td> <td>0.22</td> <td>0.19</td> <td>0.16</td> <td>0.14</td> <td>0.12</td> <td>0.10</td> <td>0.10</td> <td>0.08</td> </tr> </table>									Rated Voltage (V)	6.3	10	16	25	35	50	63	100	D.F. (tan δ)	0.22	0.19	0.16	0.14	0.12	0.10	0.10	0.08									
	Rated Voltage (V)	6.3	10	16	25	35	50	63	100																											
	D.F. (tan δ)	0.22	0.19	0.16	0.14	0.12	0.10	0.10	0.08																											
	<table border="1"> <tr> <td>Rated Voltage (V)</td> <td>160</td> <td>200</td> <td>250</td> <td>350</td> <td>400</td> <td>450</td> <td></td> <td></td> </tr> <tr> <td>D.F. (tan δ)</td> <td>0.16</td> <td>0.18</td> <td>0.18</td> <td>0.20</td> <td>0.20</td> <td>0.20</td> <td></td> <td></td> </tr> </table>									Rated Voltage (V)	160	200	250	350	400	450			D.F. (tan δ)	0.16	0.18	0.18	0.20	0.20	0.20											
Rated Voltage (V)	160	200	250	350	400	450																														
D.F. (tan δ)	0.16	0.18	0.18	0.20	0.20	0.20																														
When the capacitance exceeds 1,000 μ F, 0.02 shall be added every 1,000 μ F increase.																																				
Stability at Low Temperature (at 120Hz)	Impedance ratio shall not exceed the values given in the table below.																																			
	<table border="1"> <tr> <td>Rated Voltage (V)</td> <td>6.3</td> <td>10</td> <td>16</td> <td>25</td> <td>35</td> <td>50</td> <td>63</td> <td>100</td> </tr> <tr> <td>Z(-25°C) / Z(+20°C)</td> <td>4</td> <td>3</td> <td>2</td> <td>2</td> <td>2</td> <td>2</td> <td>2</td> <td>2</td> </tr> <tr> <td>Z(-40°C) / Z(+20°C)</td> <td>8</td> <td>6</td> <td>4</td> <td>4</td> <td>3</td> <td>3</td> <td>3</td> <td>3</td> </tr> </table>									Rated Voltage (V)	6.3	10	16	25	35	50	63	100	Z(-25°C) / Z(+20°C)	4	3	2	2	2	2	2	2	Z(-40°C) / Z(+20°C)	8	6	4	4	3	3	3	3
	Rated Voltage (V)	6.3	10	16	25	35	50	63	100																											
	Z(-25°C) / Z(+20°C)	4	3	2	2	2	2	2	2																											
Z(-40°C) / Z(+20°C)	8	6	4	4	3	3	3	3																												
<table border="1"> <tr> <td>Rated Voltage (V)</td> <td>160</td> <td>200</td> <td>250</td> <td>350</td> <td>400</td> <td>450</td> <td></td> <td></td> </tr> <tr> <td>Z(-25°C) / Z(+20°C)</td> <td>2</td> <td>2</td> <td>3</td> <td>5</td> <td>15</td> <td>15</td> <td></td> <td></td> </tr> </table>									Rated Voltage (V)	160	200	250	350	400	450			Z(-25°C) / Z(+20°C)	2	2	3	5	15	15												
Rated Voltage (V)	160	200	250	350	400	450																														
Z(-25°C) / Z(+20°C)	2	2	3	5	15	15																														
After the rated voltage has been applied for 2,000 hours at 85°C																																				
Load Life	Capacitance Change	Within \pm 20% of initial value																																		
	D.F. (tan δ)	150% or less of initial specified value																																		
	Leakage Current	less than initial specified value																																		
Shelf Life	After storage for 500 hours at 85°C, with no voltage applied and being stabilized at +20°C, Capacitor shall meet the limit specified in load life.																																			

Dimensions (Units:mm)

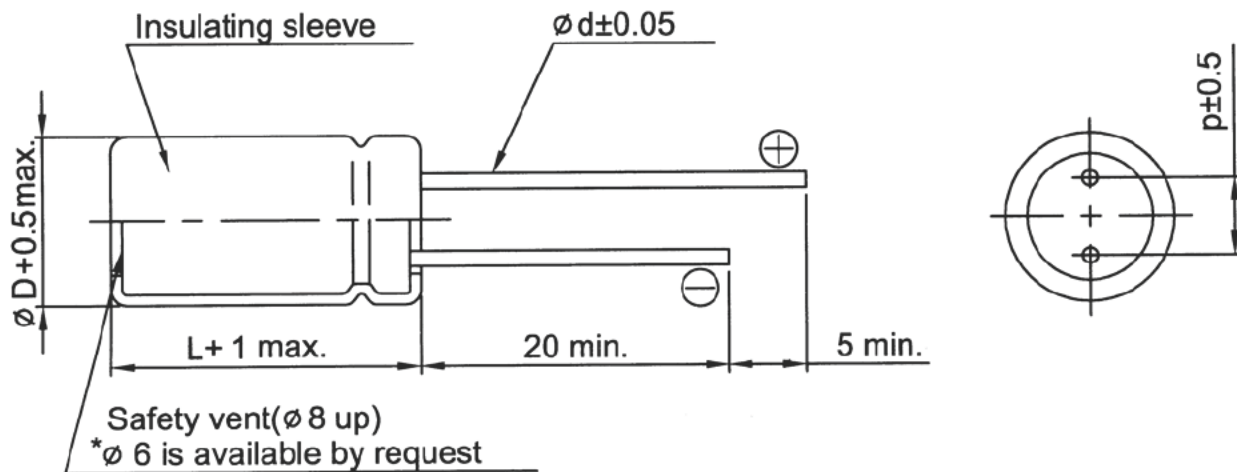

D ϕ	5.0	6.3	8.0	10	13	16	18	22	25
F	2.0	2.5	3.5	5.0	5.0	7.5	7.5	10.0	12.5
d ϕ	0.5			0.6		0.8		1.0	

