

## DF52 Series

# 0.8mm Pitch, Compact and Robust Wire-to-Board Connectors



Power Supply



Robust



Compact

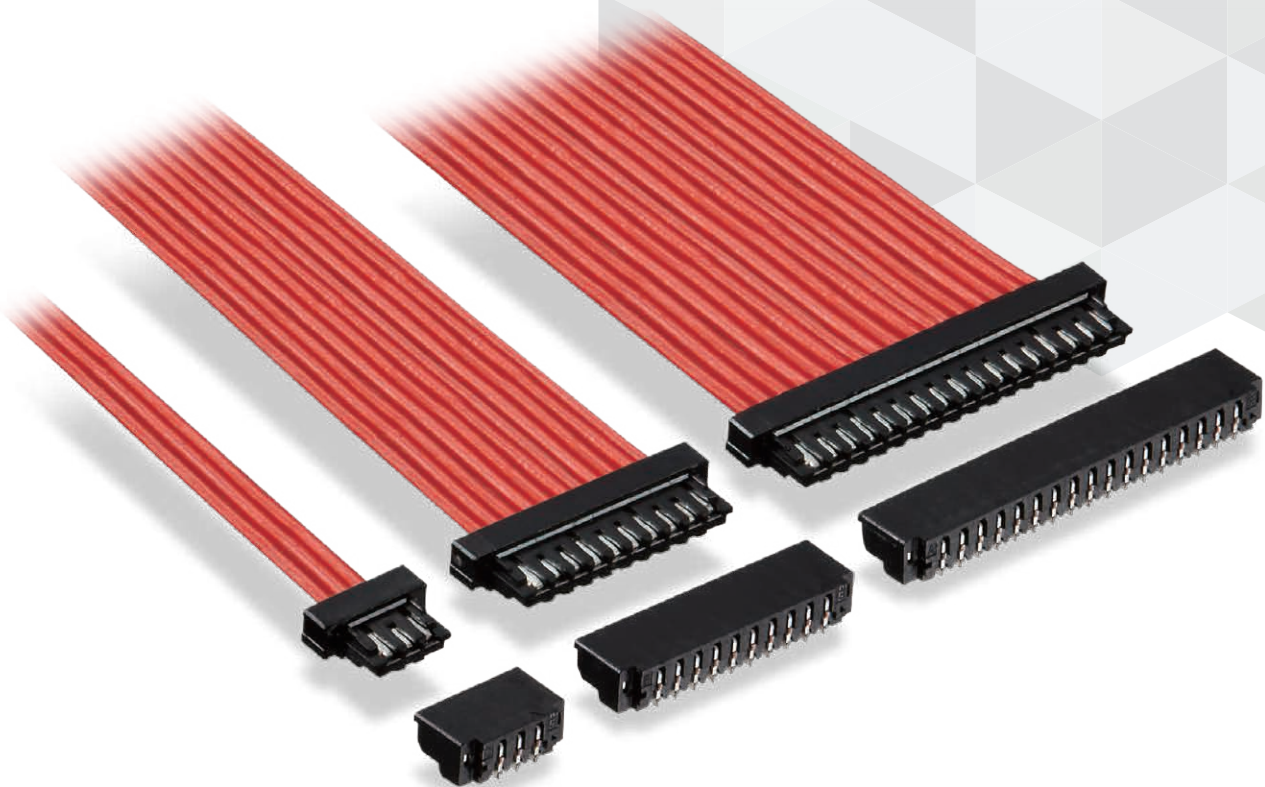

# Features

## 1. Small-Sized Connector

0.8mm Pitch, 1.75mm Height, 4.1mm Depth.  
Suitable for small-sized applications.

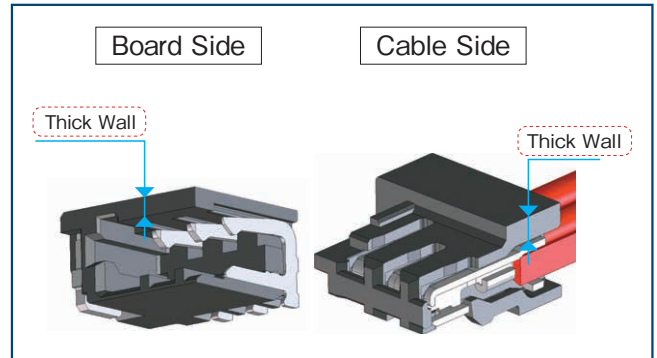

Thick Housing Walls and Compact Size.

## 2. Compact yet Robust Design

The housing wall thickness is secured in necessary areas while maintaining a compact size, resulting in a robust design despite its small size.

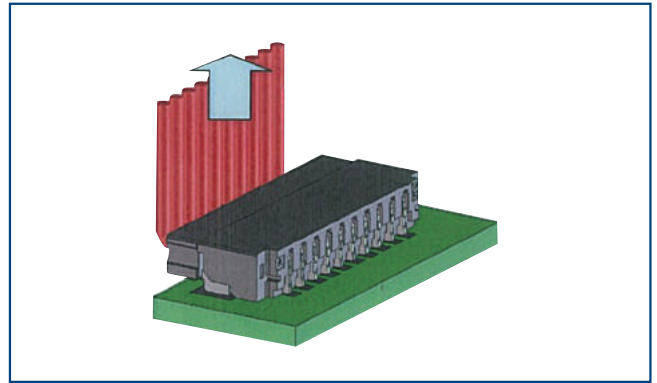

Robust design prevents damage while wire routing.

## 3. Suitable for High Current Applications (2.5A Max. : using 2pos. and 28 AWG)

High current in small size is supported by the use of highly conductive materials and an optimized contact force to lower contact resistance value.

## 4. Box shaped contact prevents deformation.

The box shaped crimp contact prevents deformation during assembly and contributes to the overall stability and robustness.

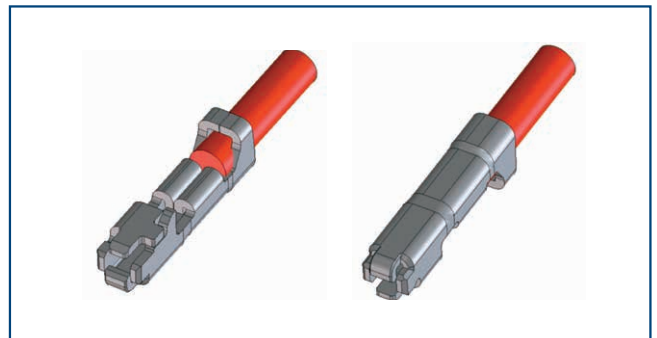

Box Shaped Contact Design

## 5. Visual check insures fully mated Plug and Receptacle

The housing is designed with an open side that allows for visual inspection to insure the connectors are fully mated, preventing accidental disconnect.

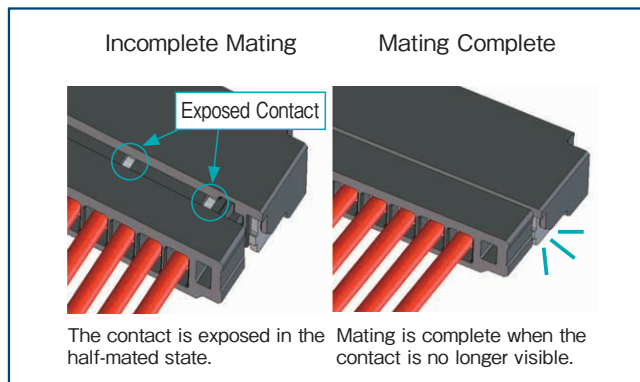

Allows for visual inspection of the mating process  
(The mated condition can be visually checked)

## 6. Halogen-free

No chlorine or bromine exceeding the standard values are used in this connector.

\* As defined by IEC 61249-2-21

Br : 900ppm Max. , Cl : 900ppm Max. ,

Br+Cl : 1500ppm Max.

## Product Specifications

Rated Current	No. of Pos.	28 AWG	30 AWG	32 AWG	Operating Temperature (Note 1)	-40 to +85°C
	2	2.5A/pin	2A/pin	1.5A/pin	Storage Temperature Range (Note 2)	-10 to +60°C
	3	2A/pin	1.5A/pin	1A/pin	Operating Humidity Range (Note 3)	20 to 80%
	4	2A/pin	1.5A/pin	1A/pin	Storage Humidity Range (Note 2)	40 to 70%
	5	2A/pin	1.5A/pin	1A/pin		
	6	1.5A/pin	1.2A/pin	0.8A/pin		
	8	1.5A/pin	1.2A/pin	0.8A/pin		
	10	1.5A/pin	1.2A/pin	0.8A/pin		
	12	1.2A/pin	1A/pin	0.8A/pin		
	14	1.2A/pin	1A/pin	0.8A/pin		
	15	1.2A/pin	1A/pin	0.8A/pin		
	16	1.2A/pin	1A/pin	0.8A/pin		
	17	1.2A/pin	1A/pin	0.8A/pin		
	20	1.2A/pin	1A/pin	0.8A/pin		
Rated Voltage	100V AC/DC					

Note 1 : Includes the temperature rise caused by current flow.

Note 2 : The term "storage" refers to the long-term storage condition of unused products before PCB mounting.

Operating temperature/humidity range is applied to the deenergized state after mounting of PCB and the temporary storage state during transportation.

Note 3 : Use without condensation.

Note 4 : Information contained in this catalog represents general requirements for this Series.

Please contact us for the drawings and specifications for a specific part number shown.

Items	Specifications	Conditions
Insulation Resistance	100M $\Omega$ Min.	Measured at 100V DC
Withstanding Voltage	No flashover dielectric breakdown	300V AC applied for 1 min.
Contact Resistance (Under Low Voltage and Current)	10 m $\Omega$ Max.	Measured at 20mV DC, 1mA (DC or 1000Hz)
Vibration Resistance	No electrical discontinuity of 1 $\mu$ s or more.	10 cycles in each of three axis at frequency 10-55Hz, half amplitude 0.75mm
Shock Resistance	No electrical discontinuity of 1 $\mu$ s or more.	Acceleration of 490 m/s <sup>2</sup> , 11ms, half-sine wave 3 directions 3 times each
Moisture Resistance	Contact Resistance : 20m $\Omega$ Max. Insulation Resistance : 100M $\Omega$ Min.	Temperature : 40 $\pm$ 2°C ; Humidity : 90 to 95%, for 96 hours
Temperature Cycle	Contact Resistance : 20m $\Omega$ Max. Insulation Resistance : 100M $\Omega$ Min.	(-55°C : 30 min. $\rightarrow$ +5 to +35°C : 2 to 3 min. $\rightarrow$ +85°C : 30 min. $\rightarrow$ +5 to +35°C : 2 to 3 min.) 5 cycles
Mating Durability	Contact Resistance : 20m $\Omega$ Max.	20 times
Solder Heat Resistance	No dissolution of housing parts that affect performance.	Reflow : according to the Recommended Temperature Profile Manual soldering : temperature of soldering iron at 350 $\pm$ 10°C for 3 seconds

## Materials / Finish

Product	Part	Materials	Finish	Remarks
Receptacle	Insulator	Polyamide	Black	UL94V-0
	Contact	Copper Alloy	Tin Plating	-
Crimp Plug	Insulator	Polyamide	Black	UL94V-0
Crimp Contact	Contact	Copper Alloy	Tin Plating	-

## Product Number Structure

Refer to the chart below when determining the product specifications from the product number.  
Please select from the product numbers listed in this catalog when placing orders.

### ■ Receptacle

#### **DF52 - # S - 0.8 H**

①      ② ③      ④      ⑤

① Series Name	DF52	③ Connector Type	S : Receptacle
② No. of Pos.	2, 3, 4, 5, 6, 8, 10, 12, 14, 15, 16, 17, 20	④ Contact Pitch	0.8mm
		⑤ Termination Style	H : SMT Right Angle Type

### ■ Plug Connector

#### **DF52 - # P - 0.8 C**

①      ② ③      ④      ⑤

① Series Name	DF52	③ Connector Type	P : Crimp Plug
② No. of Pos.	2, 3, 4, 5, 6, 8, 10, 12, 14, 15, 16, 17, 20	④ Contact Pitch	0.8mm
		⑤ Termination Style	C : Crimp Plug

### ■ Crimp Contact

#### **DF52 - 2832 PCF**

①      ②      ③

① Series Name	DF52	② Applicable Wire Size	2832 : 28 to 32 AWG
		③ Type Classification/ Packaging	PCF : Plug Crimp Contact / reel

## Right Angle Receptacle

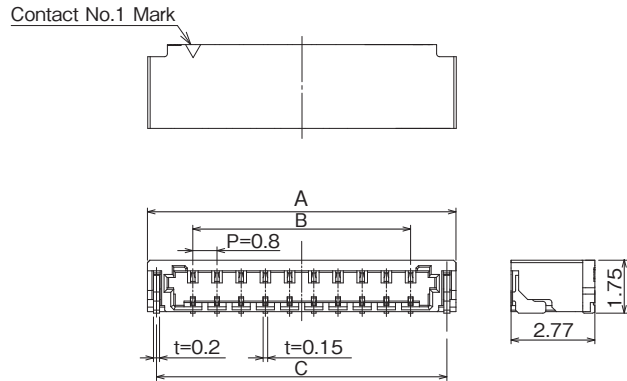

Unit : mm

Part No.	HRS No.	No. of Pos.	A	B	C	Purchase Unit
DF52-2S-0.8H(21)	CL0668-0004-5-21	2	3.8	0.8	3.2	5,000pcs per reel
DF52-3S-0.8H(21)	CL0668-0022-7-21	3	4.6	1.6	4.0	
DF52-4S-0.8H(21)	CL0668-0005-8-21	4	5.4	2.4	4.8	
DF52-5S-0.8H(21)	CL0668-0023-0-21	5	6.2	3.2	5.6	
DF52-6S-0.8H(21)	CL0668-0006-0-21	6	7.0	4.0	6.4	
DF52-8S-0.8H(21)	CL0668-0007-3-21	8	8.6	5.6	8.0	
DF52-10S-0.8H(21)	CL0668-0008-6-21	10	10.2	7.2	9.6	
DF52-12S-0.8H(21)	CL0668-0009-9-21	12	11.8	8.8	11.2	
DF52-14S-0.8H(21)	CL0668-0024-2-21	14	13.4	10.4	12.8	
DF52-15S-0.8H(21)	CL0668-0010-8-21	15	14.2	11.2	13.6	
DF52-16S-0.8H(21)	CL0668-0025-5-21	16	15.0	12.0	14.4	
DF52-17S-0.8H(21)	CL0668-0001-7-21	17	15.8	12.8	15.2	
DF52-20S-0.8H(21)	CL0668-0011-0-21	20	18.2	15.2	17.6	

[Specification Number] (21) : Tin plating, embossed packaging

### ● Recommended PCB Layout

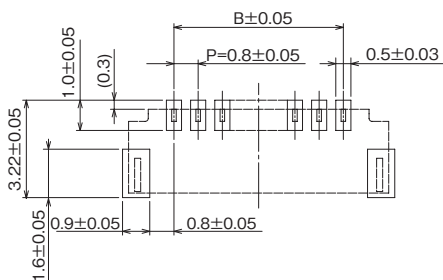

## ■ Packaging Specification

### ● 2 to 17pos.

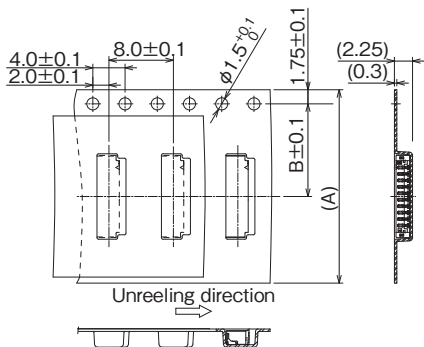

### ● 20pos.

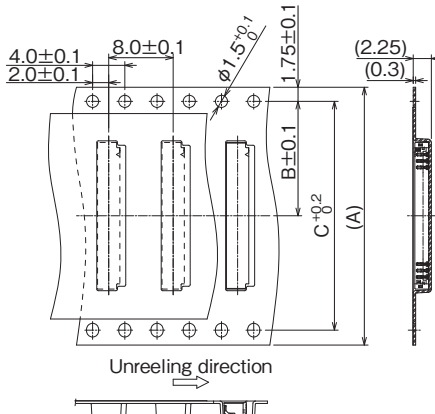

### ● Reel Dimensions

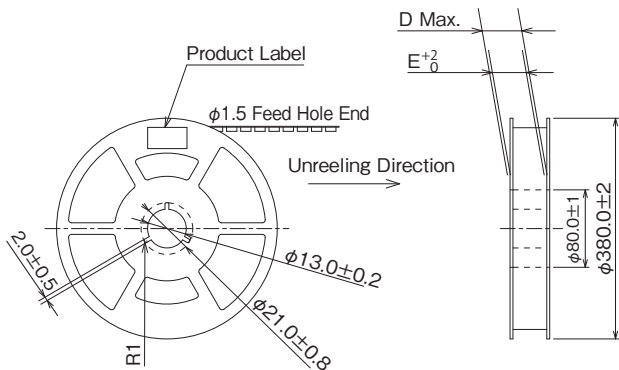

Unit : mm

Part No.	No. of Pos.	A	B	C	D	E
DF52-2S-0.8H(21)	2	16.0	7.5		22.4	16.4
DF52-3S-0.8H(21)	3					
DF52-4S-0.8H(21)	4					
DF52-5S-0.8H(21)	5					
DF52-6S-0.8H(21)	6	24.0	11.5		30.4	24.4
DF52-8S-0.8H(21)	8					
DF52-10S-0.8H(21)	10					
DF52-12S-0.8H(21)	12					
DF52-14S-0.8H(21)	14					
DF52-15S-0.8H(21)	15					
DF52-16S-0.8H(21)	16	32.0	14.2	28.4	38.4	32.4
DF52-17S-0.8H(21)	17					
DF52-20S-0.8H(21)	20					

## Crimp Plug

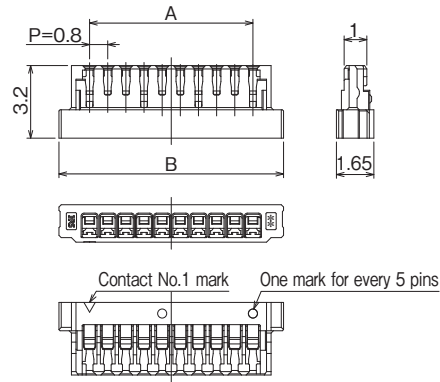

Unit : mm

Part No.	HRS No.	No. of Pos.	A	B	Purchase Unit
DF52-2P-0.8C	CL0668-0013-6-00	2	0.8	3.5	100pcs per bag
DF52-3P-0.8C	CL0668-0026-8-00	3	1.6	4.3	
DF52-4P-0.8C	CL0668-0014-9-00	4	2.4	5.1	
DF52-5P-0.8C	CL0668-0027-0-00	5	3.2	5.9	
DF52-6P-0.8C	CL0668-0015-1-00	6	4.0	6.7	
DF52-8P-0.8C	CL0668-0016-4-00	8	5.6	8.3	
DF52-10P-0.8C	CL0668-0017-7-00	10	7.2	9.9	
DF52-12P-0.8C	CL0668-0018-0-00	12	8.8	11.5	
DF52-14P-0.8C	CL0668-0028-3-00	14	10.4	13.1	
DF52-15P-0.8C	CL0668-0019-2-00	15	11.2	13.9	
DF52-16P-0.8C	CL0668-0029-6-00	16	12.0	14.7	
DF52-17P-0.8C	CL0668-0002-0-00	17	12.8	15.5	
DF52-20P-0.8C	CL0668-0020-1-00	20	15.2	17.9	



## Crimp Contact

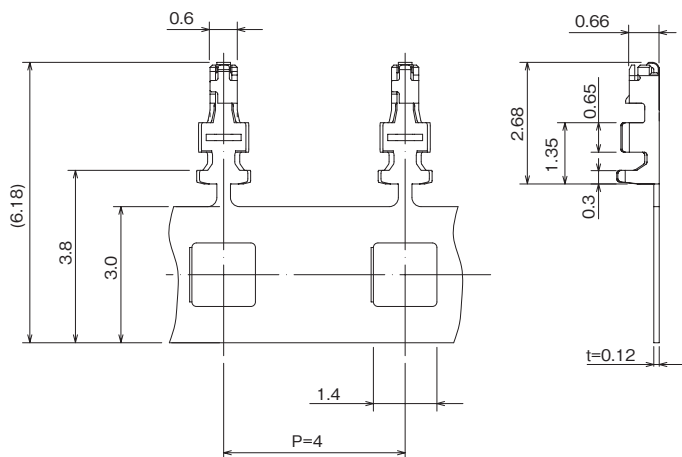

Part No.	HRS No.	Type	Purchase Unit
DF52-2832PCF	CL0668-0030-5-00	Reel Contact	40,000pcs per reel

### ● Applicable Wire (Tinned Annealed Copper Wire)

Conductor Size (Core Wire Configuration)	Jacket Outer Diameter	Recommended Wire	Strip Length
28 AWG (7pcs/0.127mm in diameter)	φ 0.5 to 0.6mm	UL1571 (thin line)	0.9 to 1.3mm
30 AWG (7pcs/0.102mm in diameter)			
32 AWG (7pcs/0.08mm in diameter)			

Note 1 : Please contact a Hirose sales representative when using wires other than applicable wires.

Note 2 : The strip length is a reference value. Please adjust the strip length accordingly for specifications and requirements.

Refer to the Crimp Quality Standard (ETAD-H0789-00) for details.

## Applicable Crimping Tools

Type	Part No.	HRS No.	Applicable Contact	Remarks
Applicator	AP105-DF52-2832P	CL0901-4636-7-00	DF52-2832PCF	(Note 2) Manufactured by Japan Automatic Machine Co.,Ltd.
	DHS877900H-UP	-	DF52-2832PCF	
Press Body	CM-105C	CL0901-0001-0-00	-	
Extraction Tool	DF-C-PO(B)	CL0550-0179-2-00	DF52-2832PCF	

Note 1 : Issues caused by using tools other than those specified by Hirose are not covered by warranty.

Note 2 : Applicator manufactured by JAPAN AUTOMATIC MACHINE (J.A.M.). Please visit the J.A.M homepage, if you have inquiries about the applicator or crimp defects. (URL : <http://www.jam-net.co.jp>)

Note 3 : Please conduct crimping work according to the Crimp Quality Standard (ETAD-H0789-00) and crimp condition table.

Note 4 : When non-authorized tools are used, please consult with a Hirose sales representative regarding requests for the hand tool die drawing.

## Precautions

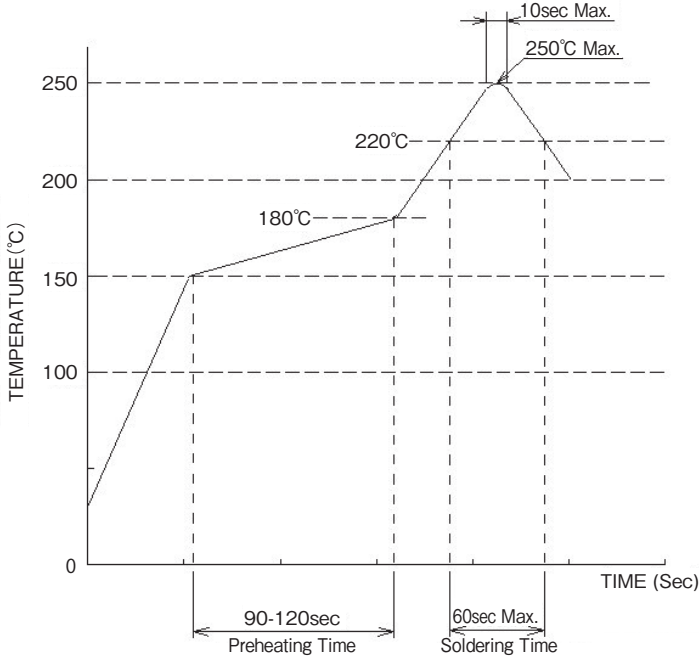
<p>Recommended Temperature Profile (Compatible With Lead-free Soldering)</p>	 <p>The graph shows a temperature profile for lead-free soldering. The y-axis is Temperature (°C) from 0 to 250. The x-axis is Time (Sec). The profile starts at 0°C, rises to 150°C, then to 180°C (labeled as the preheating area), then to 220°C, and finally to a peak of 250°C (labeled as the peak temperature). The time spent at 180°C is 90-120 seconds (labeled as Preheating Time). The time spent at 220°C and 250°C is 60 seconds maximum (labeled as Soldering Time). The peak temperature is maintained for 10 seconds maximum.</p> <p>[Applicable Conditions]</p> <ol style="list-style-type: none"> <li>1. Peak temperature : 250°C Max.</li> <li>2. Heating area : 220°C Min. for less than 60 seconds</li> <li>3. Preheating area : 150°C to 180°C for 90 to 120 seconds</li> <li>4. Number of Reflow Cycles : 2 cycles Max.</li> </ol> <p>*Measurement is conducted at the contact lead part. Soldering results may change depending on conditions such as solder paste type, manufacturer, PCB size, and other soldering materials. Please determine all mounting conditions before use.</p> <p>Note : This temperature profile is a recommended value.</p>
<p>Recommended Manual Soldering Conditions</p>	<p>Soldering Iron Temperature : 350 ± 10°C , soldering time : within 3 seconds</p>
<p>Recommended Screen Thickness and Aperture Ratio (Pattern surface ratio)</p>	<p>Thickness : 0.1mm, aperture opening ratio : 100%</p>
<p>Board Warpage</p>	<p>A maximum of 0.02mm at the center of connector, as measured from either end of the connector.</p>
<p>Cleaning Conditions</p>	<p>Cleaning is not recommended. If you clean this product, please evaluate its performance before using it. (Cleaning may impair the mating/unmating properties and lower resistance to environmental factors.)</p>
<p>Notes</p>	<ul style="list-style-type: none"> <li>■ Please note that any mating operation of the connector when not mounted on the board may cause damage or deformation of the contacts.</li> <li>■ Do not apply excessive amounts of flux during hand soldering as it may cause excess solder and flux wicking.</li> <li>■ This housing color may have slight variations depending on the production lot. This color variation does not affect performance.</li> <li>■ Please refer to "DF52 mating and unmating Procedure Document (ETAD-H0788-00)" for points in handling regarding mating operations.</li> </ul>
<p>Precautions</p>	<p>Please refer to the following documents.</p> <ul style="list-style-type: none"> <li>■ Board-to-Wire Connector Guidelines (ETAD-H1023-00)</li> <li>■ Cable Assembly Procedure (ETAD-H0791-00)</li> <li>■ Crimp Quality Standard (ETAD-H0789-00)</li> <li>■ Mating/Unmating Operation Instruction Manual (ETAD-H0788-00)</li> </ul>

## While Taking into Consideration

Specifications mentioned in this catalog are reference values.

When considering to order or use this product, please review the Drawing and Product Specifications sheets.

Use an appropriate cable when using the connector in combination with cables.

If considering usage of a non-specified cable, please contact your sales representative.

If assembly process is done by jigs & tools which are not identified by Hirose, the warranty of the product may be affected.

If considering usage for below mentioned applications, please contact your sales representative.

In cases where the application will demand a high level of reliability, such as automotive, medical instruments, public infrastructure, aerospace/defense etc. Hirose must review before assurance of reliability can be given.

**HIROSE****HIROSE ELECTRIC CO.,LTD.**2-6-3 Nakagawa Chuoh, Tsuzuki-Ku, Yokohama-Shi 224-8540, JAPAN  
<https://www.hirose.com>