

THIS DOCUMENT IS THE PROPERTY OF KEYSTONE ELECTRONICS CORP. AND SHALL NOT BE REPRODUCED, DISTRIBUTED OR USED AS A BASIS FOR MANUFACTURE WITHOUT PRIOR WRITTEN PERMISSION FROM KEYSTONE ELECTRONICS CORP.

ACTUAL SIZE

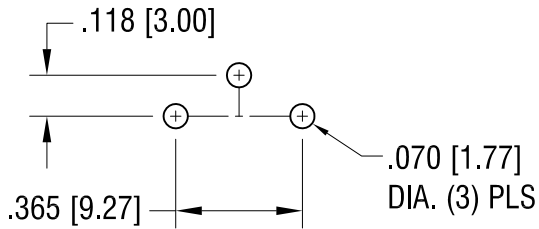

MOUNTING DETAIL

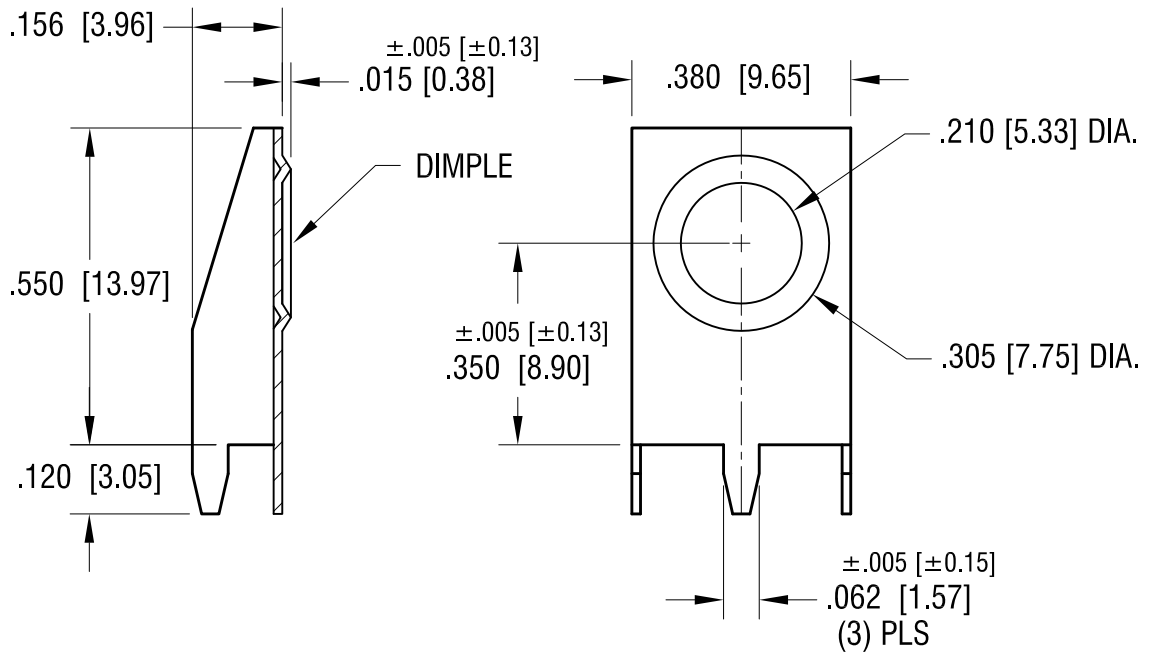

1.27.17	CHANGE AS PER ECN 17-010	D
6.24.16	CHANGE AS PER ECR 16-031	C
8.26.04	CHANGE AS PER ECN 04-071	B
4.26.99	CHANGE AS PER ECN 99-030	A
DATE	DESCRIPTION	REV.

KEYSTONE ELECTRONICS CORP.			
www.keyelco.com • ASTORIA, N.Y. 11105-2017 • Tel (718) 956-8900			
PART NAME		'A' SIZE PC BUTTON CONTACT	
MATERIAL		.015 [0.38] TH'K STEEL	
FINISH		DRN BY	DATE
TIN NICKEL PLATE		BOONE	1.7.99
		APP'D	SCALE
		LN	3X
TOLERANCES		DWG NO.	
INCH	[MM]		
DECIMAL	± .010 [± 0.25]		
ANGULAR	± 1°		
UNLESS OTHERWISE SPECIFIED		CODE	
		C	
			595